

Product availability: Stock - Normally stocked in distribution facility

Price*: 5.90 USD

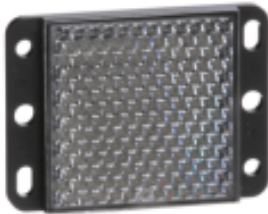

Main

Range of Product	Telemecanique Photoelectric sensors XU
Accessory / separate part category	Sensor accessories
Accessory / separate part type	Reflector
Accessory / separate part destination	Standard reflex photo-electric sensor
Shape of reflector	Square
Sale per indivisible quantity	1

Complementary

Accessory dimension	50 x 50 mm
Net Weight	0.04 Lb(US) (0.02 kg)

Ordering and shipping details

Category	22499 - SENSORS ACCESSORIES
Discount Schedule	DS2
GTIN	03389110619997
Nbr. of units in pkg.	1
Package weight(Lbs)	0.71 Oz (20 g)
Returnability	Yes
Country of origin	DE

Packing Units

Unit Type of Package 1	PCE
Package 1 Height	0.55 In (1.4 cm)
Package 1 width	3.46 In (8.8 cm)
Package 1 Length	2.99 In (7.6 cm)
Unit Type of Package 2	BAG
Number of Units in Package 2	1
Package 2 Weight	0.71 Oz (20 g)
Package 2 Height	0.55 In (1.4 cm)
Package 2 width	3.46 In (8.8 cm)

Package 2 Length	2.99 In (7.6 cm)
Unit Type of Package 3	S02
Number of Units in Package 3	100
Package 3 Weight	4.79 Lb(US) (2.174 kg)
Package 3 Height	5.91 In (15 cm)
Package 3 width	11.81 In (30 cm)
Package 3 Length	15.75 In (40 cm)

Offer Sustainability

Sustainable offer status	Green Premium product
California proposition 65	WARNING: This product can expose you to chemicals including: Diisononyl phthalate (DINP), which is known to the State of California to cause cancer, and Di-isodecyl phthalate (DIDP), which is known to the State of California to cause birth defects or other reproductive harm. For more information go to www.P65Warnings.ca.gov
REACH Regulation	REACH Declaration
EU RoHS Directive	Pro-active compliance (Product out of EU RoHS legal scope) EU RoHS Declaration
Mercury free	Yes
RoHS exemption information	Yes
Environmental Disclosure	Product Environmental Profile
Circularity Profile	End Of Life Information

Contractual warranty

Warranty	18 months
----------	-----------

Dimensions

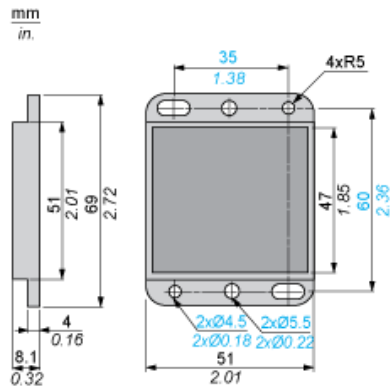

Product Life Status : Commercialised